

FILTER UNIT, mobile with water separator

Series UMW 80 PN 6

Sheet No.
4016 B

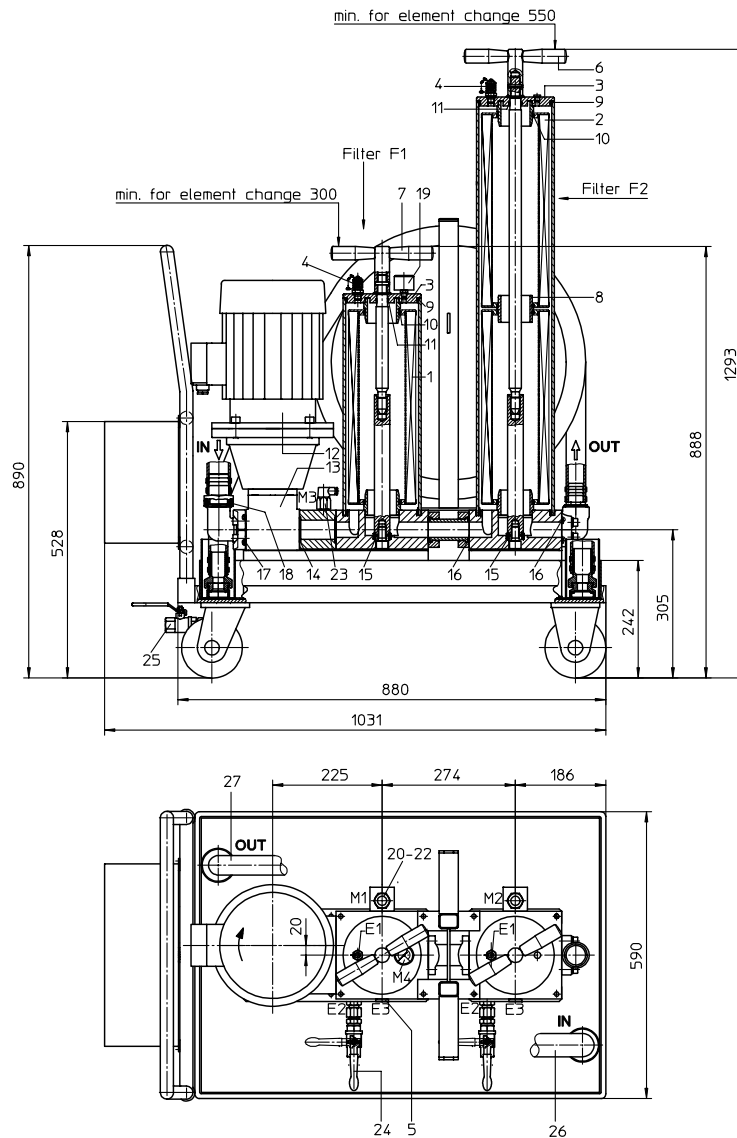

Assignment of connections and functions:

E1: venting mini-measuring connection MA.1.St see sheet-no. 1650
E2: drainage of filter, dirt side
E3: drainage of filter, clean side

M1/M2: measure connection at filter housing
M3: measure connection in front of the filters
M4: measure connection in the housing cover, dirt side

1. Type index:

1.1. Filter Unit: (ordering example)

UMW. 80. 1261. P. 1. 2. P09. D04. AOR. AOR. E5. O

1	2	3	4	5	6	7	8	9	10	11	12
---	---	---	---	---	---	---	---	---	----	----	----

1 series:

UMW = filter unit, mobile with water separator

2 nominal size filter unit: 80

3 nominal size der water separator unit: 1261

4 sealing material:

P = Nitrile (NBR)

V = Viton (FPM), by agreement

5 filter element in the filter 1:

1 = standard-return-line filter element, see item 1.2.

6 filter element in the filter 2:

2 = standard-return-line filter element, see item 1.3.

7 pump unit:

P09 = pump unit 09, NG 80.50

8 motor:

D04 = B5/100L/4.2.2.1500.230/400.D.50.1.-.- rotary current motor 230/400 V, 50 Hz, approx. 1420 rpm, 2,2 KW, type of protection IP 54

9 clogging indicator at M1:

AOR = AOR.2.5.P.- clogging indicator visual, 2,5 bar see sheet-no. 1606

10 clogging indicator at M2:

AOR = AOR.2.5.P.- clogging indicator visual, 2,5 bar see sheet-no. 1606

11 clogging indicator at M3:

E5 = E5.5 pressure switch, contact breaker, 5 bar see sheet-no. 1616

12 clogging indicator at M4:

O = clogging indicator visual, 6,0 bar see sheet-no. 1616

1.2. Filter element: (ordering example)

01NR. 630. 6VG. 10. B. P. -

1	2	3	4	5	6	7
---	---	---	---	---	---	---

1 series:

01NR. = standard-return-line filter element, DIN 24550, T4

2 nominal size: 630

3 filter-material and filter-fineness:

10 VG = 10 $\mu\text{m}_{(c)}$, 6 VG = 7 $\mu\text{m}_{(c)}$, 3 VG = 5 $\mu\text{m}_{(c)}$,

1 VG = 4 $\mu\text{m}_{(c)}$ Interpor fleece (glass fibre)

4 resistance of pressure difference for filter element:

10 = Δp 10 bar

5 filter element design:

B = both sides open

6 sealing material:

P = Nitrile (NBR)

V = Viton (FPM), by agreement

7 filter element specification:

- = standard

VA = stainless steel

1.3. Filter element: (ordering example)

01NR. 630. 3WVG. 10. B. P. -

1	2	3	4	5	6	7
---	---	---	---	---	---	---

1 series:

01NR. = standard-return-line filter element, DIN 24550, T4

2 nominal size: 630

3 filter-material and filter-fineness:

10 WVG = 10 $\mu\text{m}_{(c)}$, 3 WVG = 5 $\mu\text{m}_{(c)}$

watersorp-filter element

4 resistance of pressure difference for filter element:

10 = Δp 10 bar

5 filter element design:

B = both sides open

6 sealing material:

P = Nitrile (NBR)

V = Viton (FPM), by agreement

7 filter element specification:

- = standard

Changes of measures and design are subject to alteration!

internormen
technology

Friedensstrasse 41, 68804 Altlusheim, Germany

phone +49 - (0)6205 - 2094-0 e-mail sales@internormen.com
fax +49 - (0)6205 - 2094-40 url www.internormen.com



2. Spare parts:

item	designation	qty.	dimension	article-no.
1	filter element	1	01NR. 630...	
2	watersorp-filter element	2	01NR. 630...	
3	housing cover	2	30600-3	315492
4	mini-measuring connection	2	MA.1.ST	305453
5	screw plug	2	G ½	304678
6	straining screw	1	31078-3	
7	straining screw	1	30595-3	316312
8	connecting pipe	1	20899-4	308842
9	O-ring	2	140 x 6	315392 (NBR)
10	O-ring	2	70 x 4	306253 (NBR)
11	O-ring	2	22 x 3	304387 (NBR)
12	E-motor D 04	1	2,2 KW, 230/400 V	316276
13	pump unit P 09	1	NG 80.50	320268
14	O-ring	2	45 x 3	304991 (NBR)
15	O-ring	2	18 x 3	304359 (NBR)
16	O-ring	3	37,69 x 3,53	304353 (NBR)
17	O-ring	1	47,22 x 3,53	305078 (NBR)
18	O-ring	2	35 x 2,5	308893 (NBR)
19	clogging indicator visual	1	O	304907
20	clogging indicator visual	2	AOR.2.5.P.-	316431
21	O-ring	2	15 x 1,5	315357 (NBR)
22	O-ring	2	22 x 2	304708 (NBR)
23	pressure switch	1	E5.5	306165
24	evacuation connection	2	EE.3.G.ST	310449
25	evacuation connection	1	EE.3.W.ST	310534
26	suction tube 1 ½"	1	31090-4	
27	discharge hose 1 ¼"	1	31108-4	

3. Description:

The mobile filter unit is intended for oil maintenance on hydraulic systems.

The area of application comprises:

- secondary flow filtration and water separation in addition to the existing operating filter
- secondary flow filtration and water separation without the action of the operating filter
- filtration and water separation when filling the oil reservoir.

The filter unit must not be used to pump contaminated hydraulic fluids and is therefore designed without a switchover fitting to by-pass the filter. The compact structural design on a base plate without pipe satisfies the prerequisites for small dimensions and high reliability. The transporting trolley makes it possible to move close up to confined locations with difficult access, and to fix the accessories (such as hoses and the connection cable) in a safe and reliable manner.

Oil flowing out of the suction and/or discharge hose or the outflow openings is collected by the filter unit's oil trough, without causing any environmental damage. The suction tube 1 ½" and the discharge hose 1 ¼" are approximately 3000 mm long inclusive of the hose coupling.

The device is equipped with a gear pump driven by an electric motor. The flow conveyed by the geared pump is fed over a filter elements to DIN 24550, T4, nominal size 630.

Oil maintenance takes place in two stages via two in-line filters. The filter element in filter F1 ensures removal of the contamination. Depending on the customer requirements, the filter mesh in filter F1 is either 4, 5, 7 or 10 μm_(c). Water is separated in filter F2 by means of two parallel-acting water absorption filter elements.

The degree of filter element contamination is indicated on the 4 measurement points M 1 to M4.

If the permissible pressure difference of Δp1 = 2.5 bar is exceeded, the pressure difference is measured via the filter element in filter F1 and the degree of contamination is displayed at measurement point M1.

If the permissible pressure difference of Δp1 = 2.5 bar is exceeded, the pressure difference is measured via the filter element in filter F2 and the degree of contamination is displayed at measurement point M2.

The sum resulting from pressures Δp1 + Δp2 + the discharge pressure is measured at points M3 and M4.

The red sector of the gauge fitted to M4 indicates p ≤ 6 bar and so the opening of the bypass valve between the pressure and suction connection of the gear pump.

The pressure switch on M3 operates the electric control which ensures that, when the operating pressure of p = 5 bar is exceeded, the electric motor of the gear pump is switched off.

The filter unit can be operated without supervision, because operational safety is guaranteed by the switching-off function of the pressure switch fitted to M3, the overload protection of the electric motor and the bypass valve in the gear pump. After independent switching off of the filter unit by the pressure switch fitted to M3, the display condition of the pressure switch at M1 and M2 is retained, which indicates that the filter elements must be changed.

After the filter element has been changed, the contamination display at M1 and M2 must be reset manually (see data sheet 1606 for reset function).

The filter element can be changed without tools. After removing the tensioning nut and taking off the housing cover, the filter element is accessible and it can be exchanged. The filter elements are supplied complete with seals. Since it is not possible to clean the elements, the user must always keep an adequate supply of spare elements in stock.

The line, venting and draining connections are identified according to their function. Drainage is necessary when cleaning the filter unit in connection with the change of filter element, and when setting the medium.

4. Technical data:

pumping capacity:	71 l/min at 1420 rpm
E-motor:	2,2 KW, approx. 1420 rpm
rotary current	230/400 V, 50 Hz
pressure load capacity:	max. 6 bar
filter-fineness:	4, 5, 7 or 10 μm _(c)
weight:	approx. 125 kg
operating medium:	hydraulic oil based on mineral oil from 10 to 400 mm ² /s, other media on request

Classified under the Pressure Vessel Directive 97/23/EC for mineral oil (fluid group 2), Article 3, P ara. 3.
Classified under ATEX Directive 94/9/EC according to specific application (see questionnaire sheet-no. 34279-4).

5. Symbol:

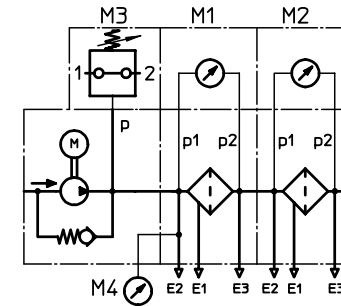

6. Test methods:

Filter elements are tested according to the following ISO standards:

ISO 2941	Verification of collapse/burst resistance
ISO 2942	Verification of fabrication integrity
ISO 2943	Verification of material compatibility with fluids
ISO 3723	Method for end load test
ISO 3724	Verification of flow fatigue characteristics
ISO 3968	Evaluation of pressure drop versus flow characteristics
ISO 16889	Multi-pass method for evaluating filtration performance