

# FILTER UNIT, mobile with fluid control

## Series UMFC 81 PN 10

Sheet No.  
4053

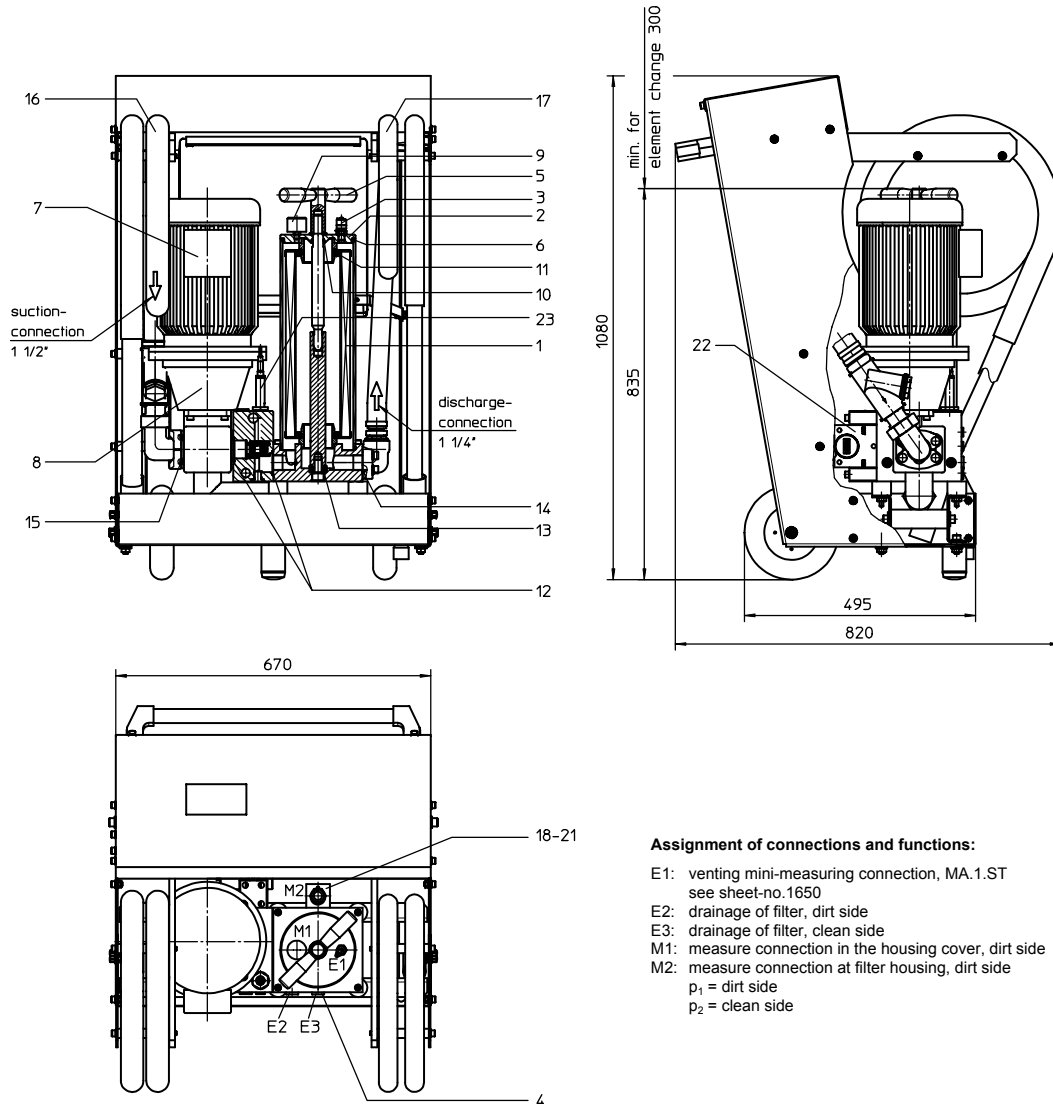

### Assignment of connections and functions:

- E1: venting mini-measuring connection, MA.1.ST see sheet-no.1650
- E2: drainage of filter, dirt side
- E3: drainage of filter, clean side
- M1: measure connection in the housing cover, dirt side
- M2: measure connection at filter housing, dirt side
- p<sub>1</sub> = dirt side
- p<sub>2</sub> = clean side

## 1. Type index:

### 1.1. Filter unit: (ordering example)

**UMFC. 81. 6VG. 10. B. P. - . P42. D63. L03. L05. AOR**

1	2	3	4	5	6	7	8	9	10	11	12
---	---	---	---	---	---	---	---	---	----	----	----

- 1 series:  
UMFC = filter unit, mobile with fluid control
- 2 nominal size: 81
- 3 filter-material and filter-fineness:  
10 VG = 10 µm<sub>(c)</sub>, 6 VG = 7 µm<sub>(c)</sub>, 3 VG = 5 µm<sub>(c)</sub>, 1 VG = 4 µm<sub>(c)</sub> Interpor fleece (glass fiber)  
10 WVG = 10 µm<sub>(c)</sub>, 3 WVG = 5 µm<sub>(c)</sub> Watersorp-filter element
- 4 resistance of pressure difference for filter element:  
10 = Δp 10 bar
- 5 filter element design:  
B = both sides open
- 6 sealing material:  
P = Nitrile (NBR)  
V = Viton (FPM), by agreement
- 7 filter element specification:  
- = standard  
VA = stainless steel  
IS06 = see sheet-no. 31601
- 8 pump unit:  
P42 = pump unit 42, NG 80.50 (standard-pump unit)
- 9 motor: (D = rotary current motor)

motor	electrical connection	volume flow	max. viscosity	doc.-no.
D63 <sup>1)</sup>	230/400V	50Hz	35,5 l/min	800 mm <sup>2</sup> /s
	230/400V	50Hz	71,0 l/min	400 mm <sup>2</sup> /s
	265/460V	60Hz	42,6 l/min	800 mm <sup>2</sup> /s
	265/460V	60Hz	85,2 l/min	400 mm <sup>2</sup> /s

<sup>1)</sup> standard-motor

- 10 suction connection 1 1/2" with protective filter: (see sheet-no. 31961-4)  
L03 = hose-lance-protective filter  
L04 = hose-fitting-lance-protective filter
- 11 discharge connection 1 1/4" : (see sheet-no. 31961-4)  
L05 = hose-lance  
L06 = hose-fitting-lance  
L21 = hose-fitting
- 12 clogging indicator at M2:  
- = without  
AOR = visual, Δp 2,5 bar, see sheet-no. 1606  
AOC = visual, Δp 2,5 bar, see sheet-no. 1606

## 1.2. Filter element: (ordering example)

**01NR. 630. 6VG. 10. B. P. -**

1	2	3	4	5	6	7
---	---	---	---	---	---	---

- 1 series:  
01NR. = standard-return-line filter element according to DIN 24550, T4
- 2 nominal size: 630
- 3 - 7 see type index-filter unit

### Notice:

Only operate all motors listed on this data sheet in combination with the pump unit specified on the type plate under item 8.

Changes of measures and design are subject to alteration!

## 2. Spare parts:

item	designation	qty.	dimension	article-no.
1	filter element	1	01NR. 630	
2	housing cover	1	30600-3	315492
3	mini-measuring connection	1	MA.1.ST	305453
4	screw plug	2	G ½	304678
5	straining screw	1	30595-3	316312
6	O-ring	1	140 x 6	315392 (NBR)
7	electric motor	1	according to type index	
8	pump unit P42	1	NG 80.50	327962
9	clogging indicator (series)	1	visual Ø 40	315452
10	O-ring	1	22 x 3	304387 (NBR)
11	O-ring	2	70 x 4	306253 (NBR)
12	O-ring	2	45 x 3	304991 (NBR)
13	O-ring	1	18 x 3	304359 (NBR)
14	O-ring	1	45 x 3	304991 (NBR)
15	O-ring	1	47,22 x 3,53	305078 (NBR)
16	suction hose 1 ½"	1	according to type index	
17	discharge hose 1 ½"	1	according to type index	
18	clogging indicator, visual	1	AOR or AOC	see sheet-no. 1606
19	O-ring	1	15 x 1,5	315357 (NBR)
20	O-ring	1	22 x 2	304708 (NBR)
21	O-ring	2	14 x 2	304342 (NBR)
22	contamination control sensor	1	PFS 01	327213
23	water analysis- and temperature sensor	1	WSPS 03	326211

## 3. Designation:

The mobile filter unit is intended for oil maintenance on hydraulic systems.

The area of application comprises:

- secondary flow filtration in addition to the existing operating filter
- secondary flow filtration without the action of the operating filter
- filtration when filling the oil reservoir.

The filter unit must not be used to pump contaminated hydraulic fluids and is therefore designed without a switchover fitting to bypass the filter. The compact structural design on a base plate without pipe satisfies the prerequisites for small dimensions and high reliability. The transporting trolley makes it possible to move close up to confined locations with difficult access, and to fix the accessories (such as hoses and the connection cable) in a safe and reliable manner.

Oil flowing out of the suction and/or discharge hose or the outflow openings is collected by the filter unit's oil trough, without causing any environmental damage.

The device is equipped with a gear pump driven by an E-motor. The flow conveyed by the geared pump is fed over a filter element to DIN 24550, T4, nominal size 630.

Depending on the customer's wishes, the filter fineness is either 4, 5, 7 or 10 µm<sub>(e)</sub>.

At a pressure difference > 2,5 bar, the element is polluted and has to be removed with a new element.

The filter element can be changed without tools. After removing the straining screw and taking off the housing cover, the filter element is accessible and it can be exchanged. The filter elements are supplied complete with seals. Since it is not possible to clean the elements, the user must always keep an adequate supply of spare elements in stock.

To protect against overpressure, the filter unit is fitted with a safety valve. Pressure setting about 10 bar.

The E-motor is made safe with a motor-protection-switch against overloading. At a working pressure > 10 bar, the motor-protection-switch cuts the E-motor out.

The line, venting and draining connections are identified according to their function. Drainage is necessary when cleaning the filter unit in connection with the change of filter element, and when changing the fluid medium.

In case of the drawn-off oil the contamination classes can be determined in front of the filter with the contamination control sensor PFS01, with help of the water analysis- and temperature sensor WSPS03 the saturation of the water. With choice of the different operating modes the running filter unit can be switched off manually or, after reaching the given limits for the contamination classes and / or through saturation of the water. With changing over of the pole the motor of the unit can be run either with half or full speed, which results in the given working data of item 9 in the order example.

For the protection of the pump there is a cleanable coarse filter made of metal with a mesh size of 250 µm in the suction line.

In order to protect the sensors the unit is being automatically stopped at an oil temperature of approx. 70 °C. Measurement of the contamination class with PFS01 can be done at oil temperatures up to 50 °C only. Otherwise the sensor will be overheated.

## 4. Technical data:

filter-fineness: 4, 5, 7 or 10 µm<sub>(e)</sub>  
oil temperature: 0°C to 70°C (50°C)  
weight: approx. 125 kg  
operating medium: hydraulic oil based on mineral oil from 10 mm<sup>2</sup>/s  
other media on request

Classified under the Pressure Vessel Directive 97/23/EC for mineral oil (fluid group 2), Article 3, Para. 3.  
Classified under ATEX Directive 94/9/EC according to specific application (see questionnaire sheet-no. 34279-4).

## 5. Symbol:

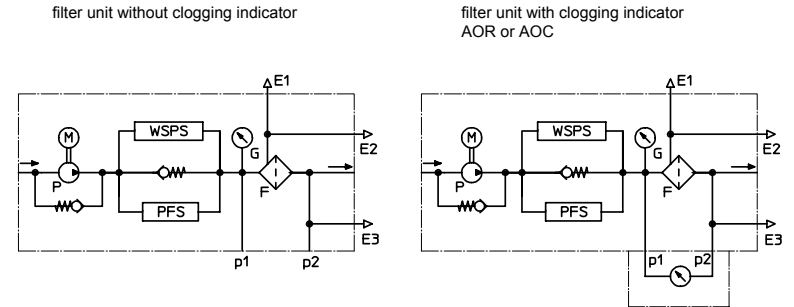

## 6. Test methods:

Filter elements are tested according to the following ISO standards:

ISO 2941	Verification of collapse/burst resistance
ISO 2942	Verification of fabrication integrity
ISO 2943	Verification of material compatibility with fluids
ISO 3723	Method for end load test
ISO 3724	Verification of flow fatigue characteristics
ISO 3968	Evaluation of pressure drop versus flow characteristics
ISO 16889	Multi-pass method for evaluating filtration performance