

# FLUID PURIFIER SYSTEMS, mobile Series IFPM 31

Sheet No.  
**4036 C**

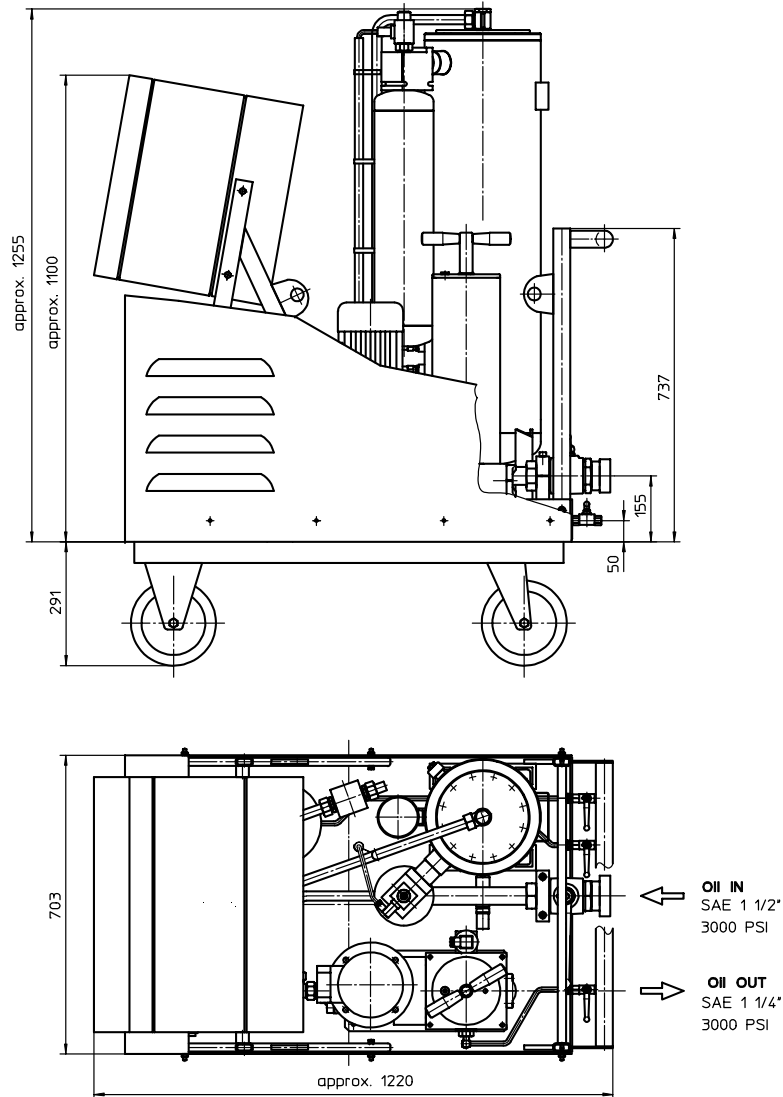

## 1. Type index:

### 1.1. Fluid Purifier Systems: (ordering example)

**IFPM. 31. 6VG. 10. B. V. -. P22. D27. VP01. VS1. A**

1	2	3	4	5	6	7	8	9	10	11	12
---	---	---	---	---	---	---	---	---	----	----	----

- 1 series:  
IFPM = INTERNORMEN-Fluid Purifier Systems, mobile
- 2 nominal size: 31
- 3 filter-material and filter-fineness:  
10 VG = 10  $\mu\text{m}_{(c)}$ , 6 VG = 7  $\mu\text{m}_{(c)}$ , 3 VG = 5  $\mu\text{m}_{(c)}$ , 1 VG = 4  $\mu\text{m}_{(c)}$  Interpor fleece (glass fibre)
- 4 resistance of pressure difference for filter element:  
10 =  $\Delta p$  10 bar
- 5 filter element design:  
B = both sides open
- 6 sealing material:  
V = Viton (FPM)
- 7 filter element specification:  
- = standard  
VA = stainless steel  
IS06 = see sheet-no. 31601
- 8 pump unit:  
P22 = pump unit 22, NG 60.40
- 9 motor:  
D27 = B5/100/8.0,75.750.230/400.D.50.1.-.-  
rotary current motor 230/400 V, 50 Hz, approx. 710 rpm, 0,75 KW, protection IP 55
- 10 vacuum pump:  
VP01 = vacuum pump 01, 230/400 V, 3- phase, 50 Hz, 0,55 KW, protection IP 55
- 11 clogging sensor:  
VS1 = VS1.1,5.V.-.GS.B.E electronic, at  $p_1$  and  $p_2$ , 1,5 bar, see sheet-no. 1607
- 12 supply voltage:  
A = 400V, 3-phase  
B = 480V, 3- phase  
C = 208V, 3- phase  
D = customised

### 1.2. Filter element: (ordering example)

**01NR. 630. 6VG. 10. B. V. -**

1	2	3	4	5	6	7
---	---	---	---	---	---	---

- 1 series:  
01NR. = standard-return-line filter element according to DIN 24550, T4
- 2 nominal size: 630
- 3 - 7 see type index- INTERNORMEN-Fluid Purifier Systems

Changes of measures and design are subject to alteration!



Friedensstrasse 41, 68804 Altlusheim, Germany

phone +49 - (0)6205 - 2094-0 e-mail sales@internormen.com  
fax +49 - (0)6205 - 2094-40 url www.internormen.com



## 2. Description:

### 2.1. Effects of Water Contamination:

Water is one of the most common contaminants and the second most destructive besides particulate contamination. Some of the most damaging problems water contamination can cause are:

- Fluid breakdown
  - Additive depletion
  - Reduction of the lubrication properties of the fluid
  - Oil oxidation
- Internal corrosion
- Abrasive wear in system components
- Reduced dielectric strength

### 2.2. Principle of Operation:

Contaminated fluid is drawn into the Internormen Fluid Purifier System by a vacuum of 0,6 to 0,9 bars.

The fluid is passing a heater which is raising the temperature in order to increase the filtration speed.

The fluid then enters through a vacuum actuated inlet valve into the vacuum chamber, where it is then allowed to cascade over the dispersal elements to break it into droplets in the tower. This increases the exposed surface area of the fluid and converts the water into vapour form, which is drawn out of the tower with a vacuum pump through the condenser to the drainage reservoir for drain off. The water-free fluid is drawn out of the tower by a hydraulic pump and sent through a high efficiency particulate removal filter back to the system.

The installed water sensor allows a permanent control of the saturation of the fluid.

## 3. Technical data:

Inlet connection:	1 ½" SAE-flange 3000 PSI
Outlet connection:	1 ¼" SAE-flange 3000 PSI
Circulation flow rate:*	30 l/min
Operating vacuum:**	0,6 to 0,9 bars
E-motor hydraulic pump:	0,75 KW, 3-phase 230/400V, 50 Hz
E-motor vacuum pump:	0,55 KW, 3-phase 230/400V, 50 Hz
Heater capacity:	3000 Watt
Filter type:	NF 631
Seal material:	Viton (FPM)
Maximum viscosity:	700 mm <sup>2</sup> /s
Water extraction rate:***	105 l/Day
weight:	approx. 325 kg

\* Viscosity of the liquid of 32 mm<sup>2</sup>/s

\*\* Operating vacuum adapted to the specific application

\*\*\* Initial rate purifying mineral oil at 32 mm<sup>2</sup>/s, 40°C and with 6% water content

## 4. Heating power characteristic:

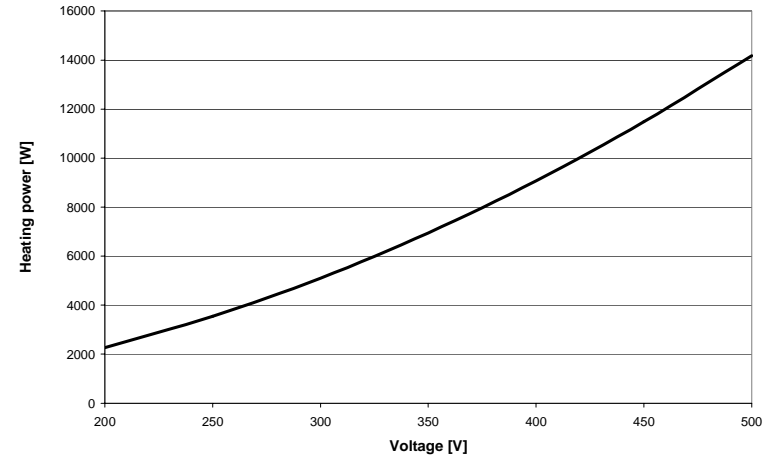

## 5. Test methods:

Filter elements are tested according to the following ISO standards:

ISO 2941	Verification of collapse/burst resistance
ISO 2942	Verification of fabrication integrity
ISO 2943	Verification of material compatibility with fluids
ISO 3723	Method for end load test
ISO 3724	Verification of flow fatigue characteristics
ISO 3968	Evaluation of pressure drop versus flow characteristics
ISO 16889	Multi-pass method for evaluating filtration performance

**Note:** Spare parts see manual and maintenance instruction „Purifier“.