

F26	
Max. static braking torque Max. coppia di frenatura statica	Nm 800
Min. brake e release pressure Min. pressione di apertura	18 bar
Max. pilot pressure Max. pressione di pilotaggio	50 bar

### Weight / Peso GMD1A + F26: 41 kg

GMD1A + F26		100	130	150	175	200	220	250	300	320
Displacement / cilindrata	cc/rev	99	129	154	172	201	221	243	290	314
Piston diameter / Diam. pistone	mm	28	32	35	37	40	42	44	48	50
Shaft stroke / Corsa albero	mm	32	32	32	32	32	32	32	32	32
Specific torque / Coppia specifica	Nm/bar	1.54	1.70	2.40	2.68	3.14	3.50	3.80	4.52	4.90
Pressure rating / Press. nominale	bar	250	250	250	250	250	250	250	250	250
Peak Pressure / Press. di picco	bar	425	400	400	375	350	350	350	300	280
Count speed / Velocità di conteggio	rpm	550	550	550	550	550	550	450	350	350
Max. speed / Velocità Max.	rpm	1000	1000	1000	900	800	700	700	650	600
Peak power / Potenza di picco	kW	48	48	48	48	48	48	48	48	48

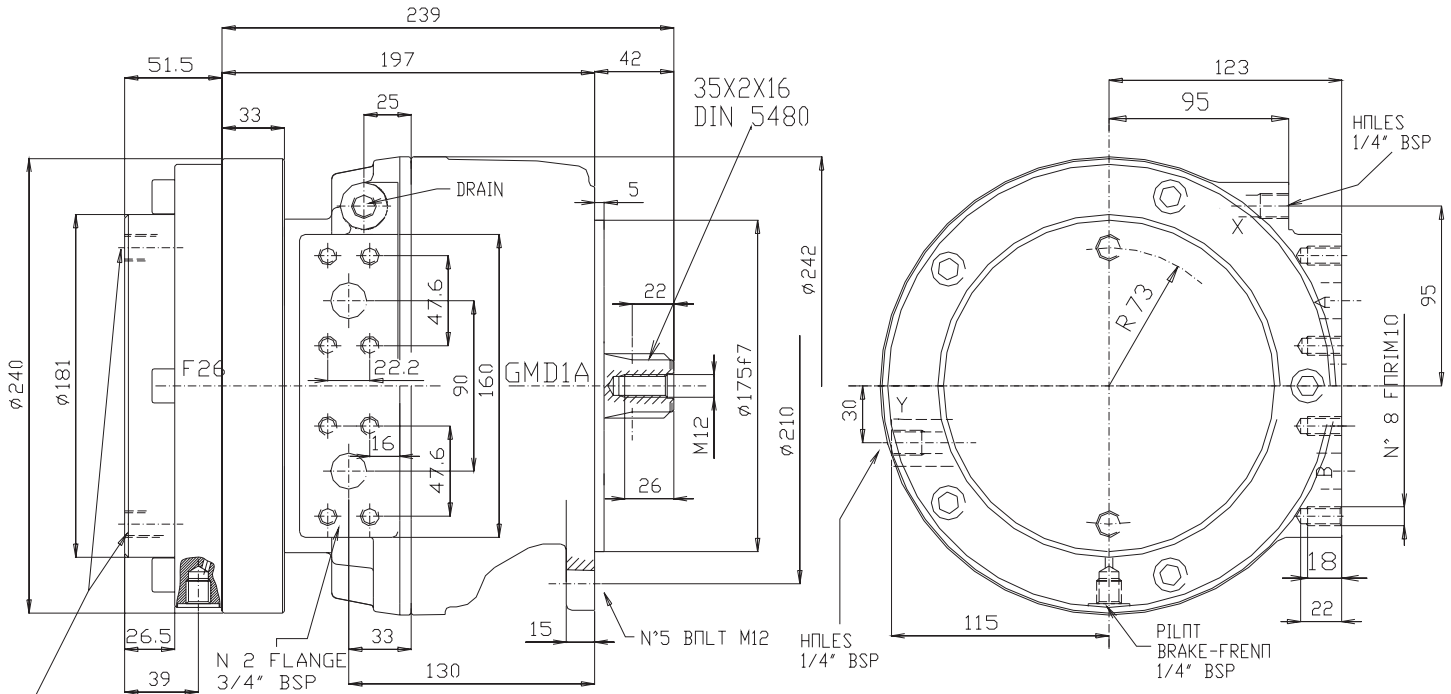

MANUAL BRAKE  
RELEASES  
SBLOCCO  
MANUALE

Interchangeable with GM1 / Intercambiabile con GM1